

DM134 、 DM135 、 DM136

Version : A.04
Issue Date : 2002/12/1
File Name : DM13x_A.04.doc
Total Pages: 18

16-Bit Constant Current LED Drivers



SITI

新竹市科學園區展業一路九號四:
SILICON TOUCH TECHNOLOGY INC.
No. 9, 4F-3 Chan-Yeh Road 1 Science-Based Industrial Park
Tel : 886-3-5645656 Fax : 886-3-5645626

DM134、DM135、DM136

16-Bit Constant Current LED Drivers

General Description

The DM134、DM135、DM136 are constant current drivers specifically designed for LED display applications. The value of constant current can be varied using an external resistor. The devices include a 16-bit shift register, latches, and constant current drivers on a single Silicon CMOS chip.

Features

- 5V CMOS Compatible Input
- Maximum Clock Frequency: 25MHz (Cascade Operation)
- Maximum Output Voltage: 17V
- Package: DIP24, SOP24, SSOP24, QFN32
- Package and Pin Layout: Pin layout and functionality are similar to those of the ST2221C. (Each characteristic value is different.)
- Constant Current Matching: ($T_a = 25^{\circ}\text{C}$ 、 $V_{DD} = 5.0\text{V}$)
Bit-to-Bit: $\pm 4.0\%$ 、Chip-to-Chip : $\pm 10.0\%$ 、
DM134: @ $I_{OUT} = 40 \sim 90\text{mA}$
DM135: @ $I_{OUT} = 10 \sim 50\text{mA}$
DM136: @ $I_{OUT} = 3 \sim 15\text{mA}$



Pin Connection (Top view)

DIP24、SOP24、SSOP24

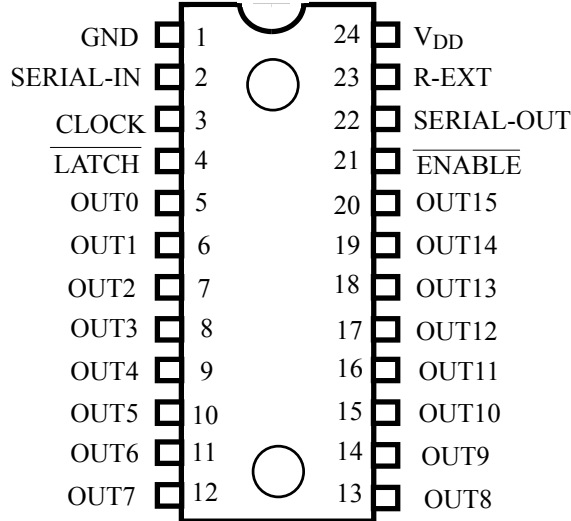

Pin Connection (Bottom view)

QFN32

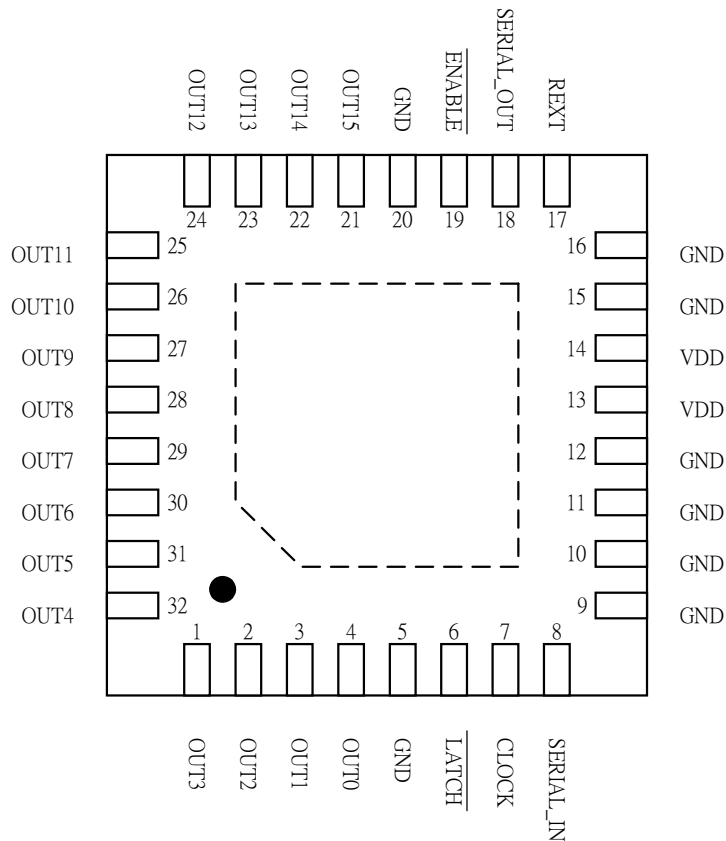



Block Diagram

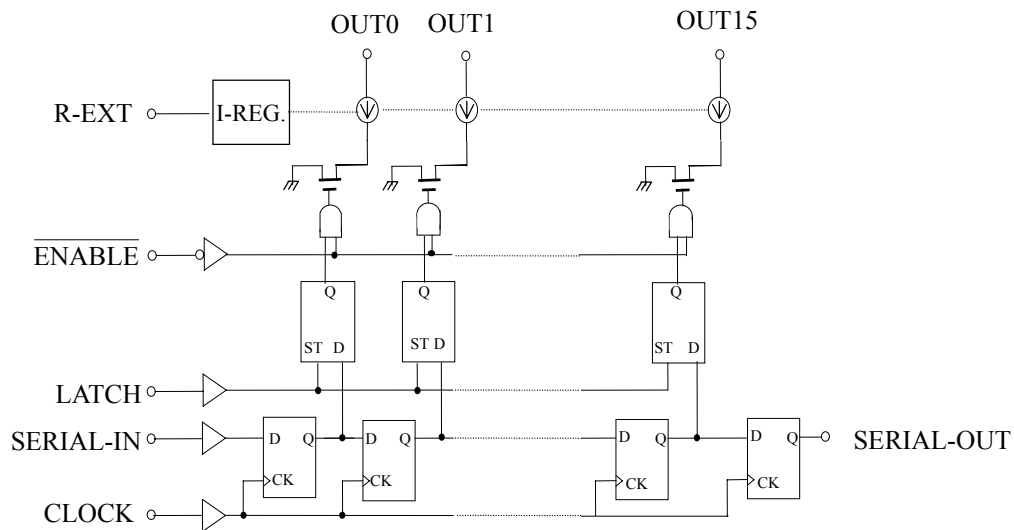

Timing Diagram

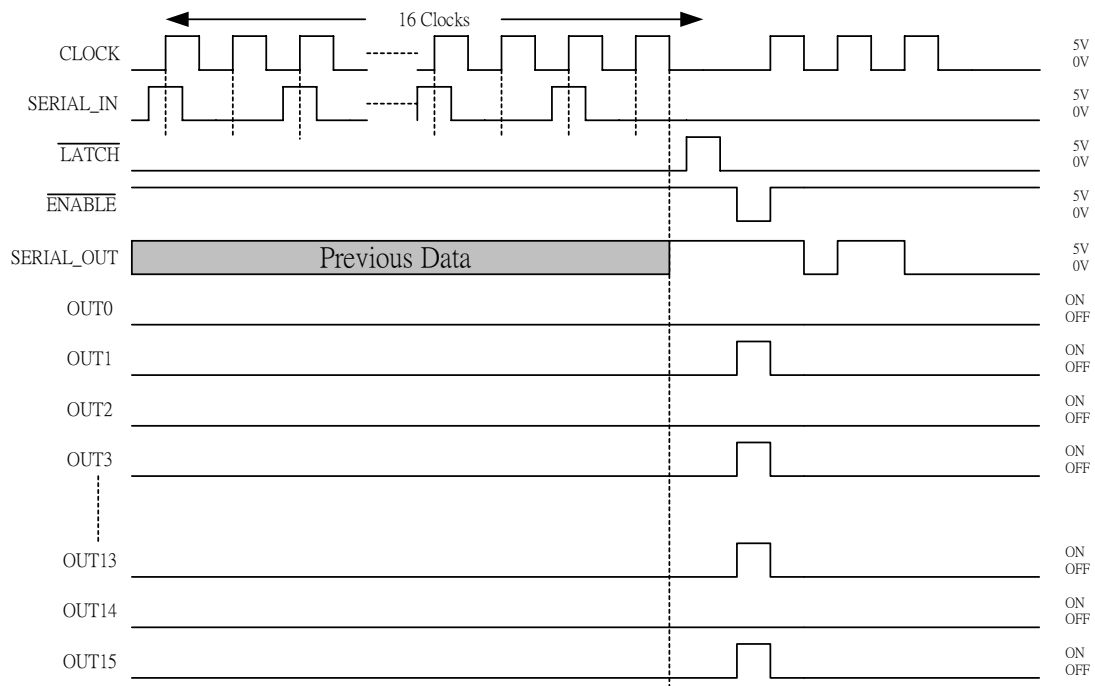

(Note) Latches are level sensitive (not edge triggered).

$\overline{\text{LATCH}}$ -terminal = H level, latches become transparent; $\overline{\text{LATCH}}$ -terminal = L level, latches hold data.

$\overline{\text{ENABLE}}$ -terminal = H level, all outputs (OUT0~15) are off.

An external resistor is connected between R-EXT and GND for setting up the value of constant current.

SERIAL-OUT changes state on the rising edges of clock.

Pin Description

PIN No.	PIN NAME	FUNCTION
1	GND	Ground terminal
2	SERIAL-IN	Input terminal of a data shift register
3	CLOCK	Input terminal of a clock for shift register
4	$\overline{\text{LATCH}}$	Input terminal of data strobe
5~20	OUT0~15	Output terminals
21	$\overline{\text{ENABLE}}$	Input terminal of output enable (active low)
22	SERIAL-OUT	Output terminal of a data shift register
23	R-EXT	Input terminal of an external resistor
24	V_{DD}	5V Supply voltage terminal

Equivalent Circuit of Inputs and Outputs

1. $\overline{\text{ENABLE}}$ terminal

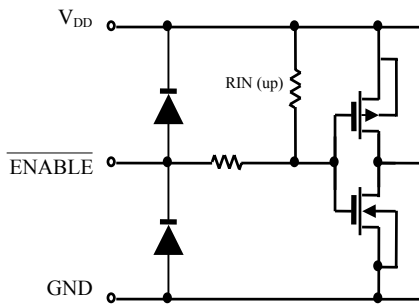

2. $\overline{\text{LATCH}}$ terminal

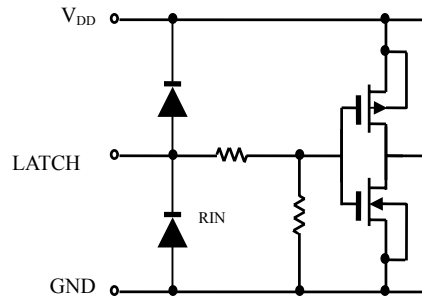

3. CLOCK, SERIAL-IN terminal

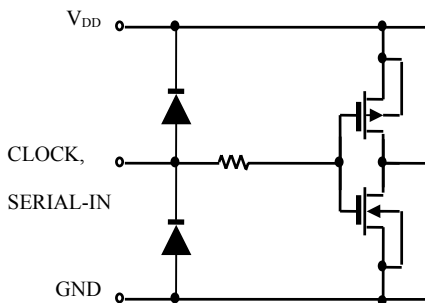

4. SERIAL-OUT terminal

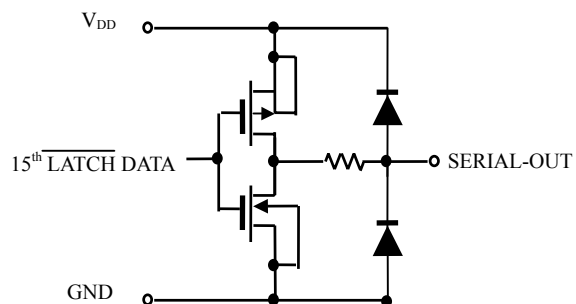

Maximum Ratings (Ta = 25°C, Tj(max) = 150°C)

CHARACTERISTIC	SYMBOL	RATING	UNIT
Supply Voltage	VDD	0 ~ 7.0	V
Input Voltage	VIN	-0.4 ~ VDD+0.4	V
Output Current	IOUT	100 (DM134)	mA
		60 (DM135)	
		20 (DM136)	
Output Voltage	VOUT	-0.3 ~ 17	V
Clock Frequency	fCLK	25	MHz
GND Terminal Current	IGND	1600 (DM134)	mA
		960 (DM135)	
		320 (DM136)	
Power Dissipation (On 4-layer PCB)	PD	2.5 (DIP-24 : Ta=25°C)	W
		1.58 (SOP-24 : Ta=25°C)	
		1.39 (SSOP-24 : Ta=25°C)	
		3.08 (QFN-32 : Ta=25°C)	
Thermal Resistance (On 4-layer PCB)	Rth(j-a)	50.0 (DIP-24)	°C/W
		79.2 (SOP-24)	
		90.2 (SSOP-24)	
		40.6 (QFN-32)	
Operating Temperature	Topr	-40 ~ 85	°C
Storage Temperature	Tstg	-55 ~ 150	°C

Recommended Operating Condition

CHARACTERISTIC	SYMBOL	CONDITION	MIN.	TYP.	MAX.	UNIT
Supply Voltage	VDD	—	4.5	5.0	5.5	V
Output Voltage	VOUT	—	—	—	17	V
Operating temperature	T _{OPR}	—	-40	—	85	°C
Output Current	IO	OUTn	5	—	85	mA
	IOH	SERIAL-OUT	—	—	1.0	
	IOL	SERIAL-OUT	—	—	-1.0	
Input Voltage	VIH	—	0.7VDD	—	VDD+0.3	V
	VIL	—	-0.3	—	0.3VDD	
LATCH Pulse Width	tw LAT	VDD = 4.5 ~ 5.5 V	15	—	—	ns
CLOCK Pulse Width	tw CLK		15	—	—	ns
Set-up Time for DATA	tsetup(D)		20	—	—	ns
Hold Time for DATA	thold(D)		20	—	—	ns
Set-up Time for LATCH	tsetup(L)		15	—	—	ns
Clock Frequency	fCLK	Cascade operation	—	—	25	MHz



Electrical Characteristics (VDD = 5.0 V, Ta = 25°C unless otherwise noted)

CHARACTERISTIC	SYMBOL	CONDITION	MIN.	TYP.	MAX.	UNIT	
Input Voltage “H” Level	VIH	—	0.7VDD	—	VDD	V	
Input Voltage “L” Level	VIL	—	GND	—	0.3VDD		
Output Leakage Current	IOH	VOH = 17 V	—	—	1.0	uA	
Output Voltage (S - OUT)	VOL	IOL = 1.0 mA	—	—	0.4	V	
	VOH	IOH = -1.0 mA	4.6	—	—		
Output Current (Bit-Bit)	ΔI_{out}	DM134 DM135 DM136 VOUT = 1.2V (1 channel on)	REXT = 377Ω	—	±1.5	±4	%
			REXT = 630Ω				
			REXT = 2100Ω				
Output Current (Chip-Chip)	Iout	DM134 DM135 DM136 VOUT = 1.2V (1 channel on)	REXT = 377Ω	36.0	40.0	44.0	mA
			REXT = 630Ω	18.9	21	23.1	
			REXT = 2100Ω	4.9	5.5	6.1	
Output Voltage Regulation	IDM134 IDM135 IDM136	Vout = 1.2V ~ 5.0V (% / Vout)	REXT = 377Ω	—	0.1	0.5	% / V
			REXT = 630Ω				
			REXT = 2100Ω				
Supply Voltage Regulation	% / VDD	Vdd = 4.5V ~ 5.5V	—	0.5	1.5	% / V	
Pull-Up Resistor	RIN(up)	—	150	300	600	KΩ	
Pull-Down Resistor	RIN(down)	—	100	200	400	KΩ	
Supply Current “OFF”	Idd (off)	DM134	REXT = OPEN, all outputs off	—	7.4	10	mA
			REXT = 210Ω, all outputs off	—	24	34	
		DM135	REXT = OPEN, all outputs off	—	7.4	10	
			REXT = 630Ω, all outputs off	—	16	22	
		DM136	REXT = OPEN, all outputs off	—	7.4	10	
			REXT = 2100Ω, all outputs off	—	12	17	
Supply Current “ON”	Idd (on)	DM134	REXT = 210Ω, all outputs on	—	26	36	
		DM135	REXT = 630Ω, all outputs on	—	18	25	
		DM136	REXT = 2100Ω, all outputs on	—	14	20	



Switching Characteristics (Ta = 25 °C unless otherwise noted)

DM134

CHARACTERISTIC		SYMBOL	CONDITION	MIN.	TYP.	MAX.	UNIT
Propagation Delay Time ("L" to "H")	ENABLE-OUTn	t _{PLH}	VDD=5.0V VIH=VDD VIL=GND	—	15	30	ns
	CLK-SOUT			—	20	25	
Propagation Delay Time ("H" to "L")	ENABLE-OUTn	t _{PHL}	REXT=210Ω VL=5.0V RL=47Ω	—	25	30	ns
	CLK-SOUT			—	20	25	
Output Current Rise Time		t _{or}	CL=13pF	30	75	150	ns
Output Current Fall Time		t _{of}		10	20	40	ns

DM135

CHARACTERISTIC		SYMBOL	CONDITION	MIN.	TYP.	MAX.	UNIT
Propagation Delay Time ("L" to "H")	ENABLE-OUTn	t _{PLH}	VDD=5.0V VIH=VDD VIL=GND	—	20	40	ns
	CLK-SOUT			—	20	25	
Propagation Delay Time ("H" to "L")	ENABLE-OUTn	t _{PHL}	REXT=630Ω VL=5.0V RL=150Ω	—	30	60	ns
	CLK-SOUT			—	20	25	
Output Current Rise Time		t _{or}	CL=13pF	25	50	100	ns
Output Current Fall Time		t _{of}		15	30	60	ns

DM136

CHARACTERISTIC		SYMBOL	CONDITION	MIN.	TYP.	MAX.	UNIT
Propagation Delay Time ("L" to "H")	ENABLE-OUTn	t _{PLH}	VDD=5.0V VIH=VDD VIL=GND	—	20	40	ns
	CLK-SOUT			—	20	25	
Propagation Delay Time ("H" to "L")	ENABLE-OUTn	t _{PHL}	REXT=2100Ω VL=5.0V RL=475Ω	—	60	120	ns
	CLK-SOUT			—	20	25	
Output Current Rise Time		t _{or}	CL=13pF	40	95	180	ns
Output Current Fall Time		t _{of}		15	35	70	ns

Test Circuit

DC characteristic

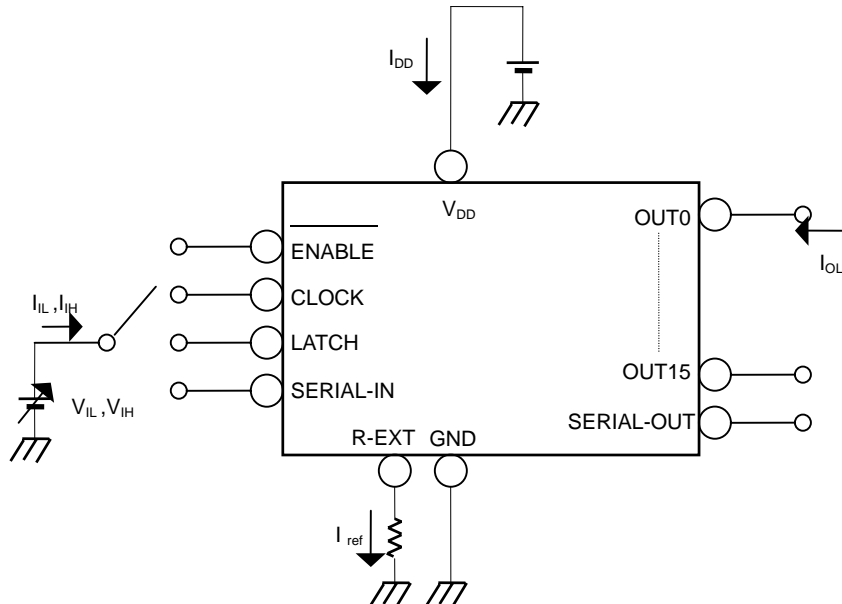

AC characteristic

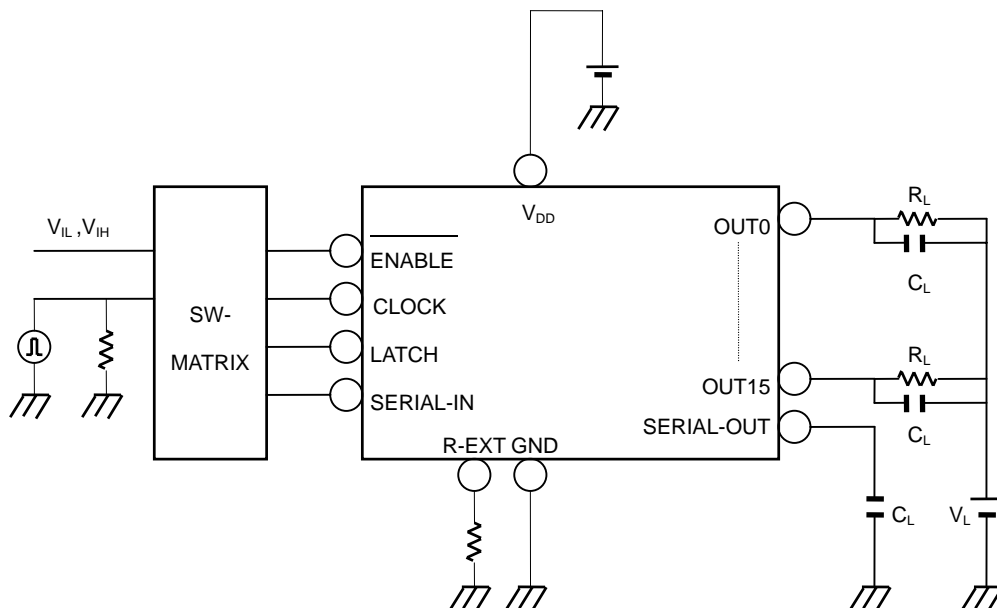



Timing Diagram

1. CLOCK-SERIAL-IN, SERIAL-OUT, OUTn (current)

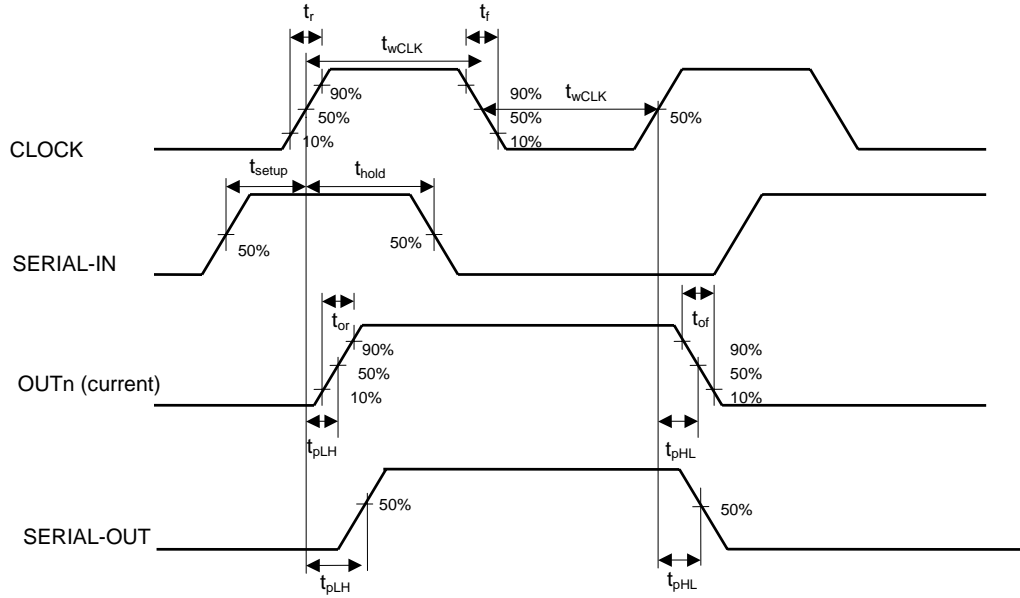

2. CLOCK-LATCH

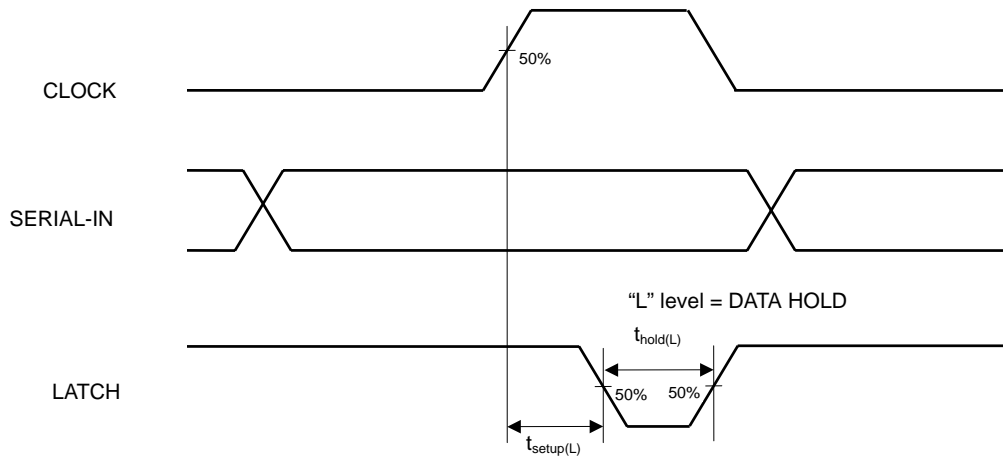

3. ENABLE-OUTn (current)

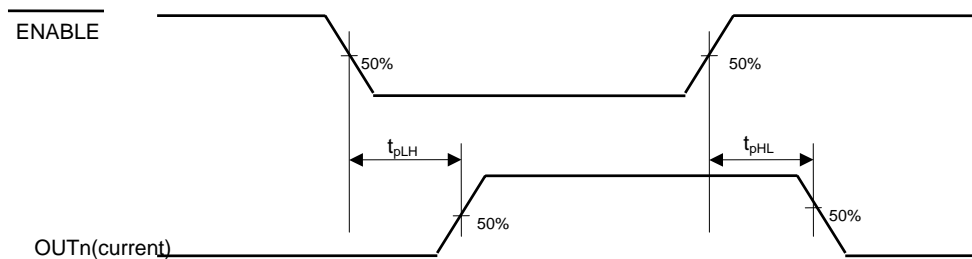



Output Current vs. External Resistor

DM134

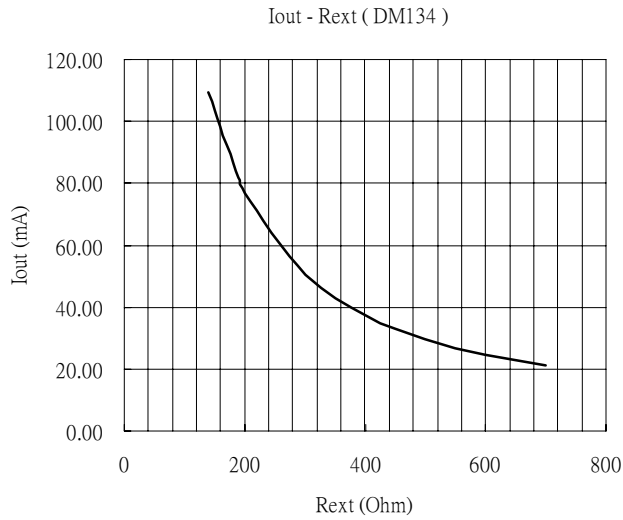

DM135

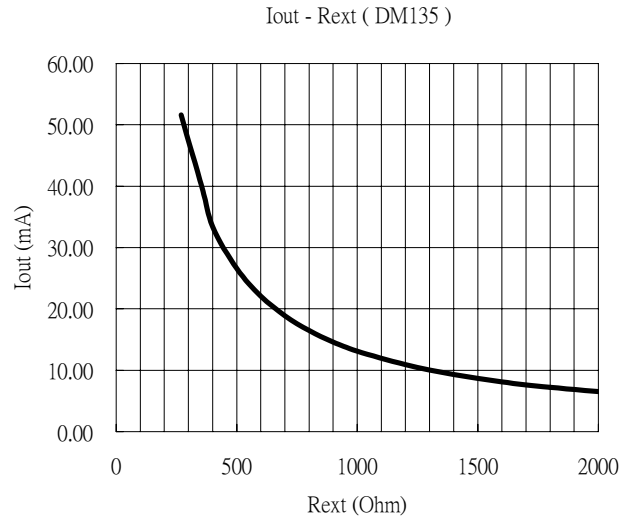

DM136

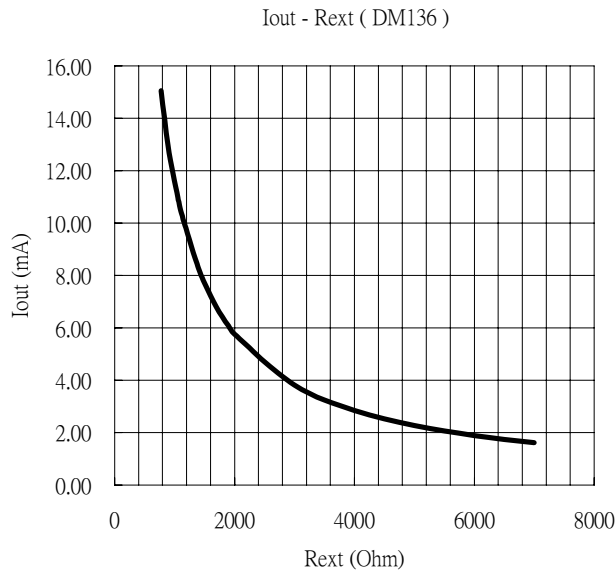

Conditions: $V_{out}=1.8V$,
 $V_{ref}=1.27V$

DM134: $I_{out} \approx V_{ref} / R_{ext} * 12$

DM135: $I_{out} \approx V_{ref} / R_{ext} * 10$

DM136: $I_{out} \approx V_{ref} / R_{ext} * 9$

Note: The resistor should be placed as close to the Rext terminal as possible to avoid the noise influence.



Output Current Performance vs. Output Voltage

DM134

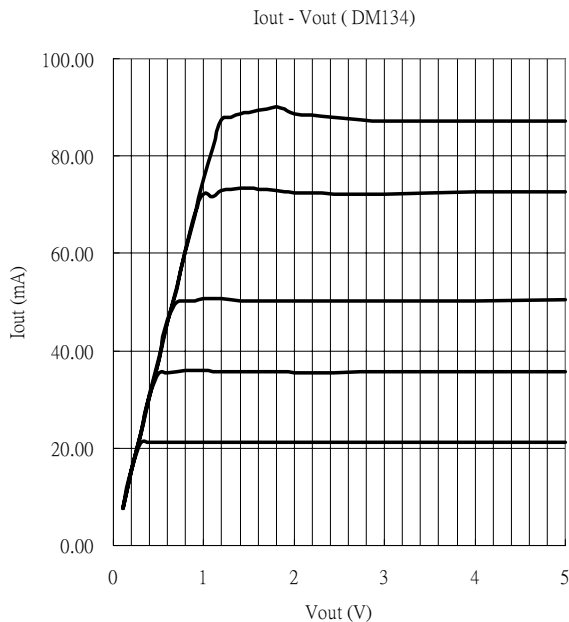

DM135

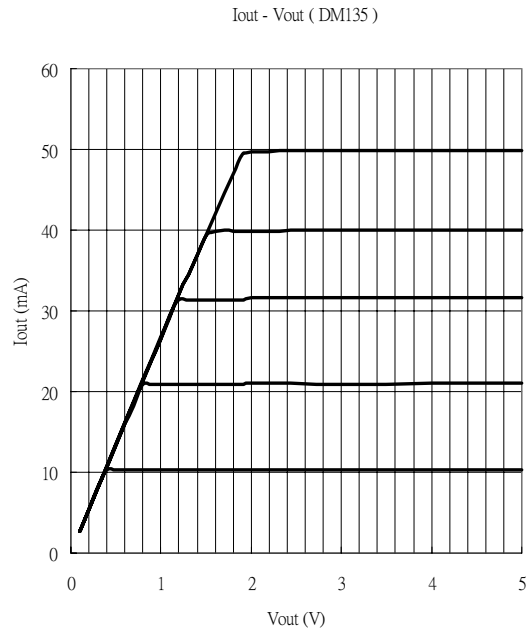

DM136

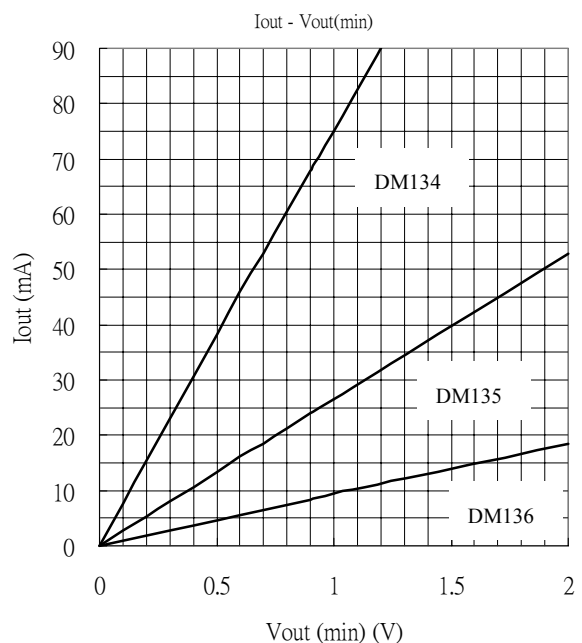
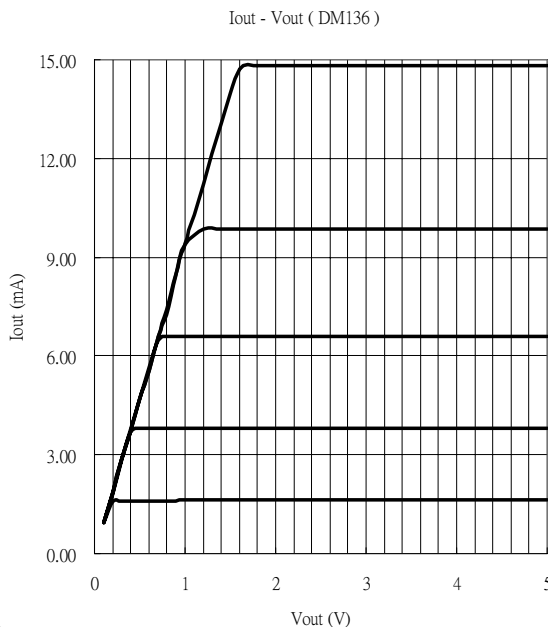

Note:

In order to obtain a good constant current output, a suitable output voltage is necessary. Users can get related information about the minimum output voltage from the above graphs. Even under the same output current condition, the minimum output voltage required for each part is different.

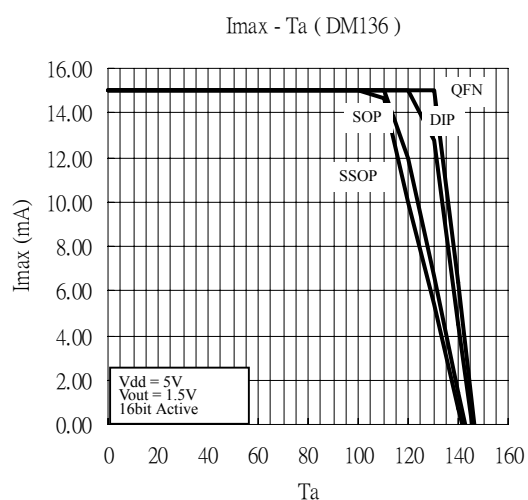
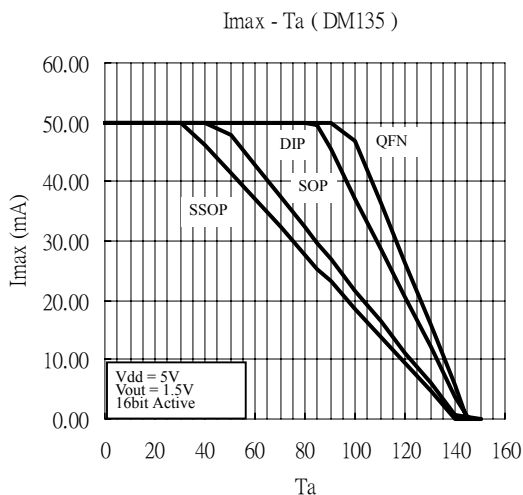
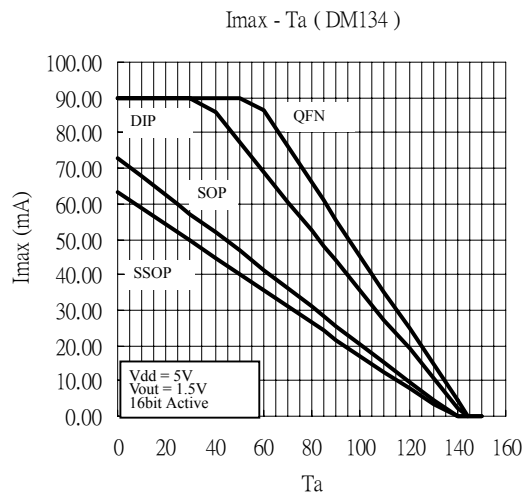
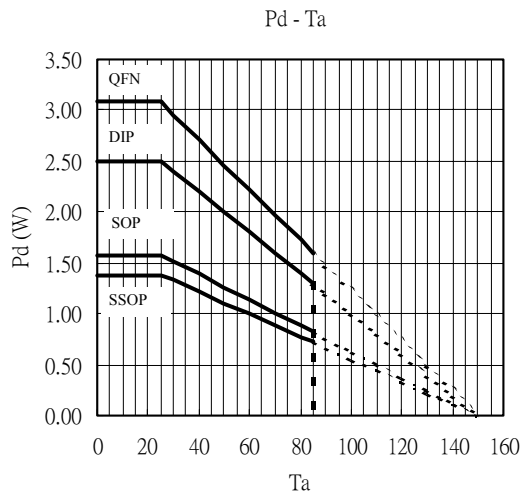

Note

As the power dissipation of a semiconductor chip is limited by its package and ambient temperature, this device requires a maximum output current given by an operating condition. The maximum allowable power consumption (Pd (max)) of this device is calculated as follows:

$$Pd(\text{max})(\text{Watt}) = \frac{(T_j(\text{junction temperature})(\text{max}) - T_a(\text{ambient temperature}))(\text{°C})}{R_{th}(\text{°C/Watt})}$$

Based on the Pd (max), the maximum allowable current can be calculated as follows:

$$I_{out} = (Pd - V_{DD} \cdot I_{DD}) / (\# \text{ outputs} \cdot V_o \cdot \text{Duty})$$

System Configuration Example

[1] Output current (I_{OUT})

Sink current is set by the external resistor as shown in the figure of I_{out} vs. R_{ext} .

[2] LED supply voltage (V_{LED}) setup

$$V_{LED} = V_{CE} (T_r V_{sat}) + V_f (\text{LED forward voltage}) + V_O (\text{IC supply voltage})$$

To prevent too much power from dissipating by the higher V_{LED} of the device, an additional R can be used to reduce the V_{out} when the outputs consume current is as follows:

$$R = \frac{V_{LED} - V_{CE} - V_f - V_O (\text{min})}{I_O (\text{max}) * \text{Bit}(\text{max})}$$

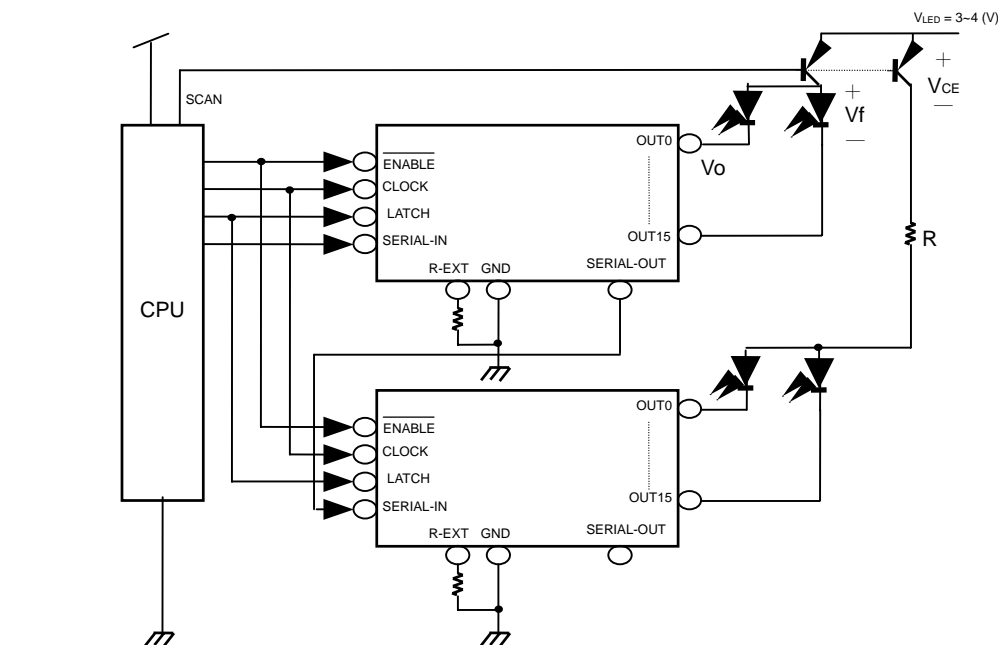

Note

This device has only one ground pin shared by signal, output sink current, and power ground. It is advisable to pattern the ground layout with minimized inductance so that the switching noise induced by the input signals and the output sink current would not cause chip malfunction. To prevent drivers' outputs from damaging by overshoot stresses, it is also advisable not to turn off the drivers and scan transistors simultaneously. For the QFN package, the IC's thermal pad, which is internally connected to the bottom side of chip, should be connected to GND. In addition, a good PCB layout pattern of the thermal pad is required in order to have a better performance in thermal effect.



Package Outline

P-DIP 24

UNIT : INCH

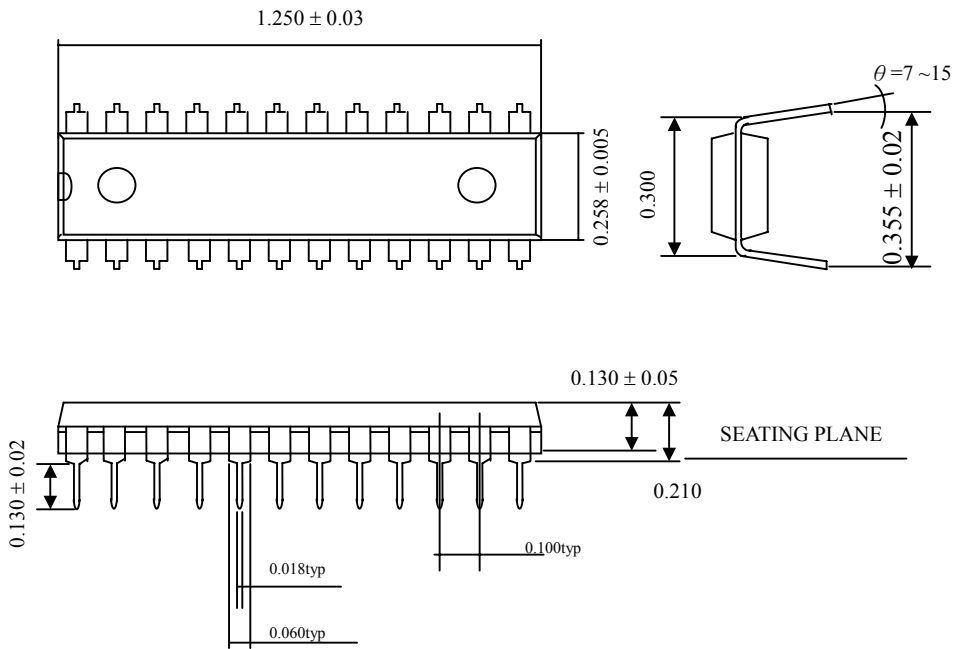



Package Outline

SOP24

UNIT : INCH

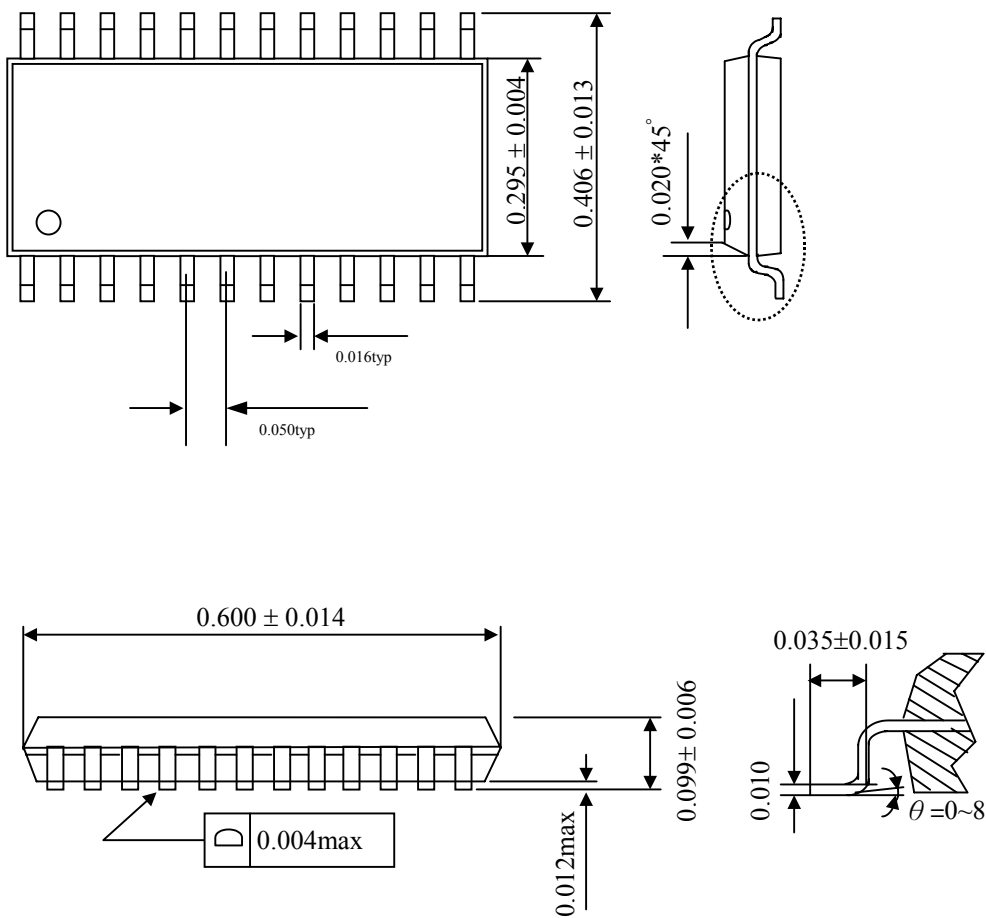



Package Outline

SSOP24

UNIT : INCH

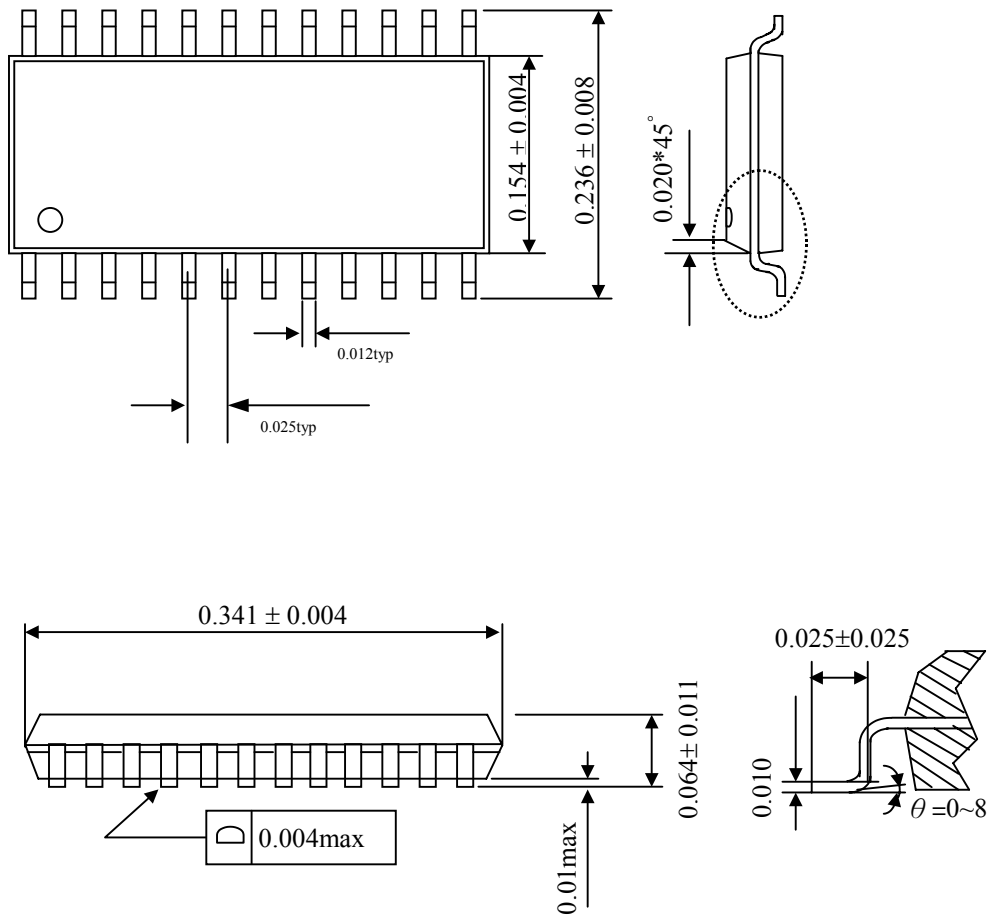



Package Outline

QFN32

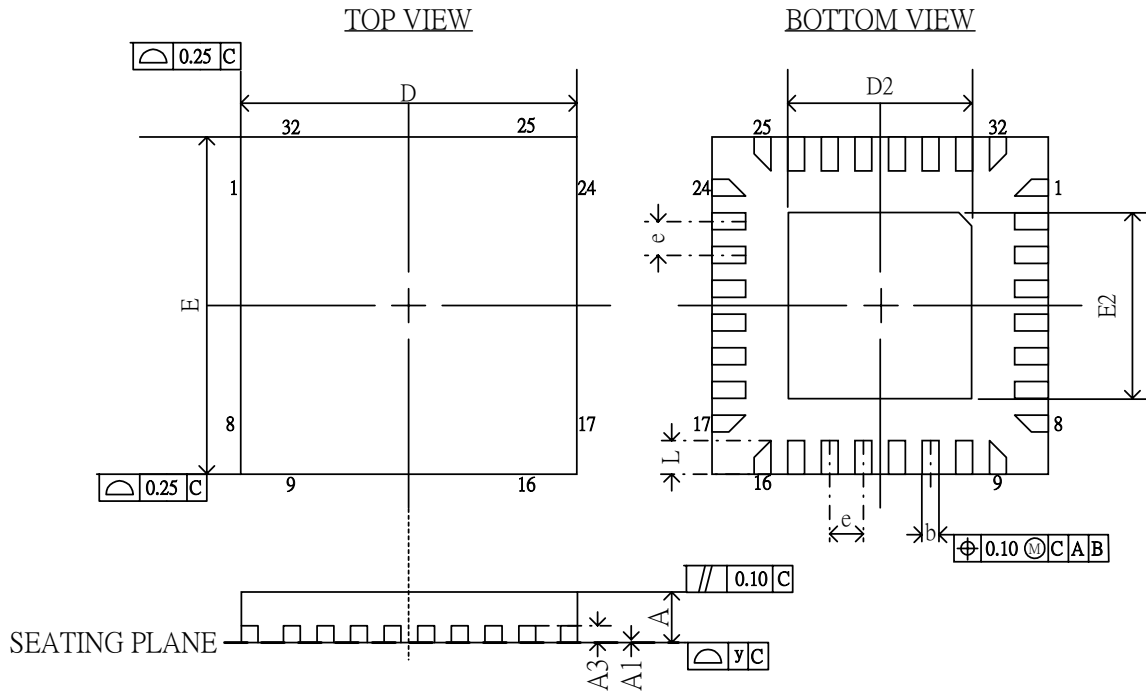

SYMBOL	DIMENSION (mm)			DIMENSION (MIL)		
	MIN.	NOM.	MAX.	MIN.	NOM.	MAX.
A	0.70	0.75	0.80	27.6	29.5	31.5
A1	0	0.02	0.05	0	0.79	1.97
A3	0.25 REF			9.84 REF		
b	0.18	0.23	0.30	7.09	9.06	11.81
D	5.00 BSC			196.85 BSC		
D2	1.25	2.70	3.25	49.21	106.30	127.95
E	5.00 BSC			196.85 BSC		
E2	1.25	2.70	3.25	49.21	106.30	127.95
e	0.50 BSC			19.69 BSC		
L	0.30	0.40	0.50	11.81	15.75	19.69
y	0.10			3.94		

Note: 1. DIMENSIONING AND TOLERANCING CONFORM TO ASME Y145.5M-1994.

2. REFER TO JEDEC STD. MO-220 WHHD-2 ISSUE A



The products listed herein are designed for ordinary electronic applications, such as electrical appliances, audio-visual equipment, communications devices and so on. Hence, it is advisable that the devices should not be used in medical instruments, surgical implants, aerospace machinery, nuclear power control systems, disaster/crime-prevention equipment and the like. Misusing those products may directly or indirectly endanger human life, or cause injury and property loss.

Silicon Touch Technology, Inc. will not take any responsibilities regarding the misuse of the products mentioned above. Anyone who purchases any products described herein with the above-mentioned intention or with such misused applications should accept full responsibility and indemnify. Silicon Touch Technology, Inc. and its distributors and all their officers and employees shall defend jointly and severally against any and all claims and litigation and all damages, cost and expenses associated with such intention and manipulation.